

NF STANDARD CONNECTIONS

# M21713

FRENCH METRIC FEMALE  
MILLIMETRIC TYPE (SLIP-ON NUT)

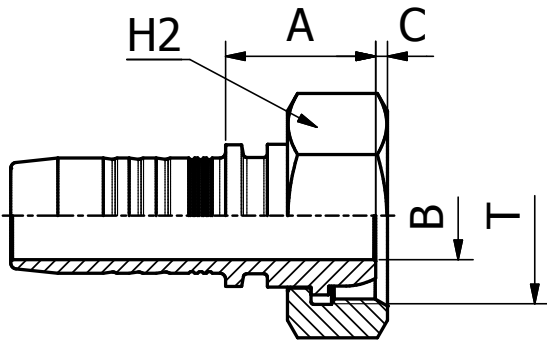

PART. REF.	HOSE BORE			Thread	Pipe	DIMENSIONS mm						
	DN	Dash	inch			T	B	A	C			
M21713-10-2718	16	-10	5/8"	M 27X1.5	18	12.5	21.5	5.0	32.0			
M21713-10-2720	16	-10	5/8"	M 27X1.5	20	12.5	21.5	5.0	32.0			
M21713-12-30	19	-12	3/4"	M 30X1.5	22	15.0	25.5	2.0	36.0			
M21713-12-33	19	-12	3/4"	M 33X1.5	25	15.0	25.5	2.0	38.0			
M21713-16-36	25	-16	1"	M 36X1.5	28	19.8	28.0	4.7	41.0			
M21713-16-39	25	-16	1"	M 39X1.5	30	19.8	28.5	4.2	46.0			

NF STANDARD CONNECTIONS

# M11810

FRENCH METRIC MALE  
24° CONE SEAT GAZ TYPE

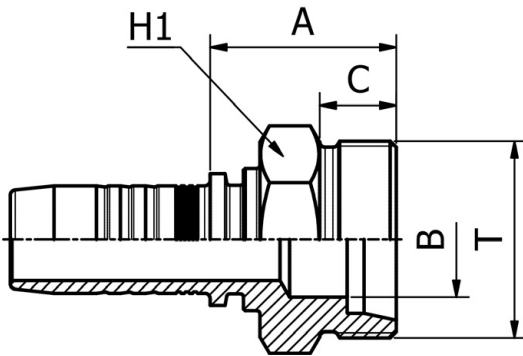

PART. REF.	HOSE BORE			Thread	Pipe	DIMENSIONS mm						
	DN	Dash	inch			T	B	A	C			
M11810-05-20	8	- 5	5/16"	M 20X1.5	13.25	8.0	27.0	12.0	22.0			
M11810-06-20	10	- 6	3/8"	M 20X1.5	13.25	8.0	27.5	12.0	22.0			
M11810-06-24	10	- 6	3/8"	M 24X1.5	16.75	12.0	28.0	12.0	24.0			
M11810-08-24	12	- 8	1/2"	M 24X1.5	16.75	12.0	28.5	12.0	24.0			
M11810-10-30	16	- 10	5/8"	M 30X1.5	21.25	15.0	31.5	14.0	30.0			
M11810-12-36	19	- 12	3/4"	M 36X1.5	26.75	21.0	34.0	14.0	36.0			
M11810-16-45	25	- 16	1"	M 45X1.5	33.5	26.0	39.5	16.0	46.0			